

# Specifications

MODEL		GTH™-6622	
MEASUREMENTS		US	Metric
Maximum lift height		22 ft 5 in	6.83 m
Reach		12 ft 9 in	3.89 m
Reach at maximum height		2 ft 6 in	0.76 m
<b>A</b> Height, stowed		6 ft 11 in	2.11 m
<b>B</b> Length, stowed (without forks)		15 ft 5 in	4.70 m
Width, standard tires		6 ft 7 in	2.01 m
<b>C</b> Wheelbase		8 ft 8 in	2.64 m
<b>D</b> Ground clearance, center		1 ft 4 in	0.41 m
<b>E</b> Ground clearance, axle		1 ft 3 in	0.38 m
Fork cross section		2 x 4 in	50 x 100 mm

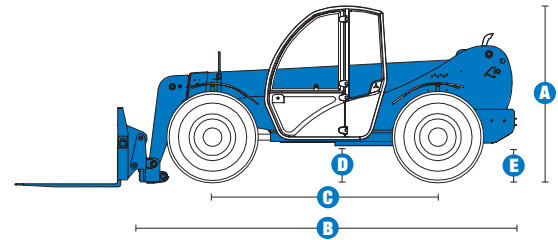

PRODUCTIVITY		
Maximum lift capacity	6,600 lbs	2,994 kg
Lift capacity at maximum height	4,400 lbs	1,996 kg
Lift capacity at maximum reach	2,700 lbs	1,225 kg
Drive speed	21 mph	33.8 km/h
Draw bar pull	14,750 lbs	6,690 kg
Turning radius, inside (4WS)	6 ft 7 in	2.01 m
Turning radius, outside (4WS)	12 ft 8 in	3.86 m
Auxiliary hydraulic flow	21 gpm	79 lpm
Auxiliary hydraulic pressure	3,915 psi	270 bar
Tires, standard size	400/70-20	

POWER		
Power source	Deutz BF4M2011 4 cylinder diesel 81 hp (60.0 kW)	
Hydraulic tank capacity	28 gal	105 liters
Hydraulic system capacity (w/tank)	38 gal	145 liters
Fuel tank capacity	24 gal	92 liters

WEIGHT		
Weight*	13,000 lbs	5,897 kg

**STANDARDS COMPLIANCE** ASME B 56.6, ISO 8471, ISO 8449

## RANGE OF MOTION GTH™-6622

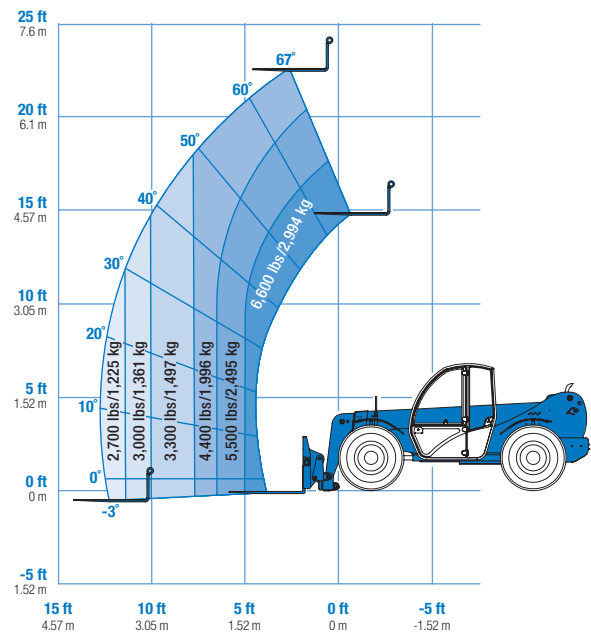

\* Weight will vary depending on options and/or country standards.

## Features

### STANDARD FEATURES

#### MEASUREMENTS

- 6,600 lb (3,000 kg) maximum lift capacity
- 22 ft 5 in (6.83 m) maximum lift height
- 12 ft 9 in (3.89 m) maximum reach

#### PRODUCTIVITY

- 4WD
- 4WS
- 2-speed hydrostatic drive
- Power assisted steering
- Internal multiple wet disc brakes
- Limited slip front axle differential
- Spring applied, hydraulic release emergency parking brake
- 400/70-20 air-filled tires
- Fenders (set of 4)
- ROPS/FOPS canopy (ISO compliant)
- Multi-function joystick controller
- Fully hydraulic proportional boom controls
- Tilt steering column
- Retractable seat belt
- Machine level indicator
- Right-side screen guard
- Genie hydraulic quick attach
- Auxiliary hydraulic circuit
- 48 in carriage
- 48 in pallet forks
- Boom angle indicator

#### POWER

- Deutz 81 hp Tier II turbo-charged diesel engine
- Cold start intake glow plug

### OPTIONS & ACCESSORIES

#### PRODUCTIVITY

- Enclosed cab, includes door, clip-in glass inserts, front wiper and tank, cab heater
- Cab air conditioner
- Adjustable suspension seat
- Flashing beacons
- Work lights

#### ATTACHING SYSTEM

- Universal attach adapter

#### ATTACHMENT OPTIONS

- Carriages
  - 48 (1.22 m) in side shift carriage
  - 48 (1.22 m) in rotating fork carriage (side tilt)
- Forks (in addition to standard 48 in pallet forks)
  - 60 in (1.52 m) forks
  - Cubing tines, 2 x 2 x 48 in (.05 x .05 x 1.22 m)
- Buckets
  - 80 in bucket with bolt-on cutting edge, .85/1.00 yd<sup>3</sup> struck/heaped
  - 78 in scrap grapple bucket
- 6 ft truss boom



#### TIRE OPTIONS

- Heavy duty 405/70-24 air-filled tires
- Heavy duty 405/70-24 foam-filled tires
- 400/70-20 foam-filled tires

### Genie United States

18340 NE 76th Street  
P.O. Box 97030  
Redmond, Washington 98073-9730

Telephone **(425) 881-1800**  
Toll Free in USA/Canada **800-536-1800**  
Fax (425) 883-3475

### Genie Europe

The Maltings,  
Wharf Road  
Grantham NG31 6BH  
U.K.

Telephone **+44 (0)1476 584333**  
Fax +44 (0)1476 584334

Email: [infoeurope@genieind.com](mailto:infoeurope@genieind.com)

### Distributed By:



**Kevin Keeter • 817.271.0405**

For further information, please contact your local distributor or the Genie Industries sales office listed. Product specifications are subject to change without notice or obligation. The photographs and drawings in this brochure are for illustrative purposes only. Refer to the appropriate Operator's Manual for instructions on the proper use of this equipment. Failure to follow the appropriate Operator's Manual when using our equipment or to otherwise act irresponsibly may result in serious injury or death. Prices and specifications subject to change without notice. The only warranty applicable is the standard written warranty applicable to the particular product and sale. Genie makes no other warranty, expressed or implied. Products and services listed may be trademarks, service marks or trade-names of TEREX Corporation and/or its subsidiaries in the USA and other countries and all rights are reserved. Copyright © 2006 Genie Industries, Inc. "Genie" is a Registered Trademark of Genie Industries, Inc. in the USA and many other countries. Genie is a TEREX Company.